

PRODUCT CODE: MP28
CHANNEL BRACKET

DESCRIPTION

21mm U Bracket

FINISH

Hot Dipped Galvanised

MATERIAL

Steel

PACKAGING

Packed in qty 25

ADDITIONAL NOTES

Compliant to LU Standard 1-085 (for use on surface & sub-surface locations)

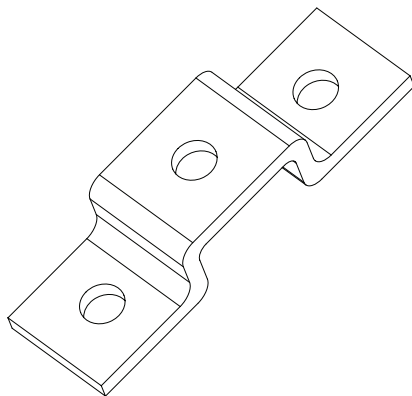
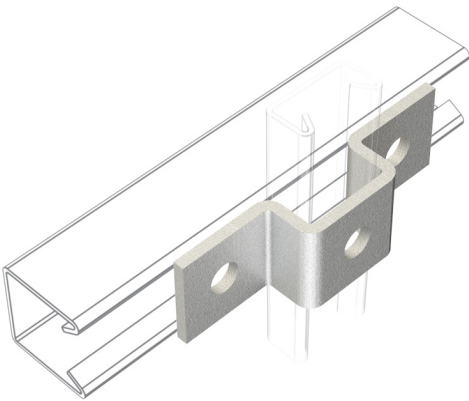

Isometric view

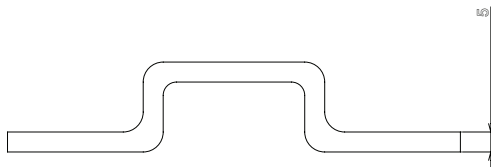

Side view

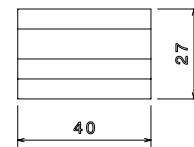

Front view

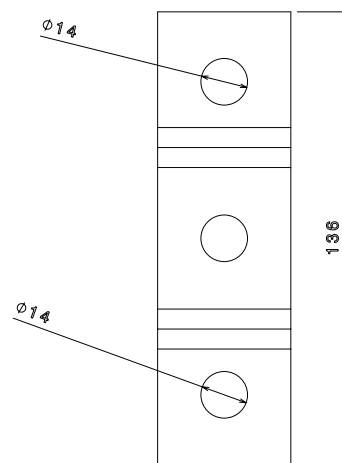

Top view